

Levitronix Pump System BPS-3

Max. Differential Pressure: 3.5 bar 50 psi
 Max. Flow: 50 l/min 13 gal/min
 Max. Liquid Temperature: 85 °C 185 °F
 Wet Materials: PTFE, PFA, PVDF, ECTFE
 Supply Voltage: 72 V and 48 V (DC)



Figure 7: Levitronix® Pump System BPS-3

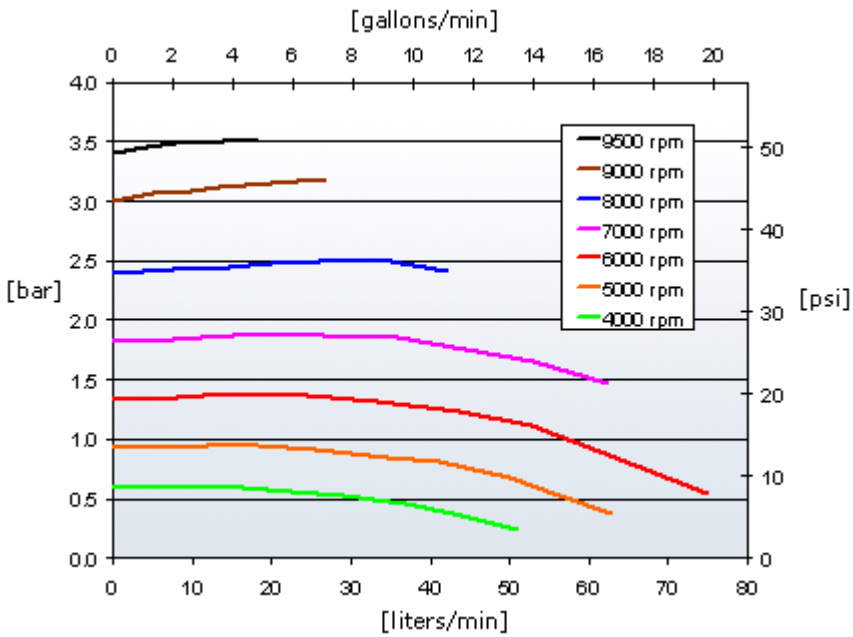
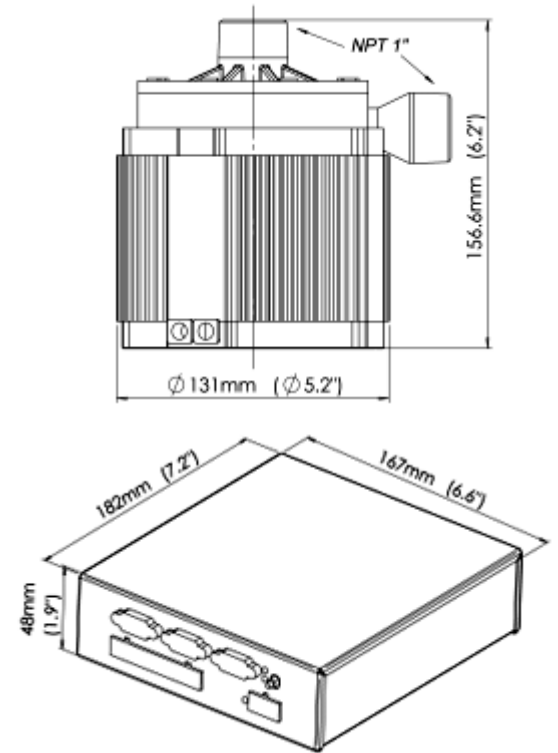

Figure 8: Pressure-flow curves for BSP-3 with water @ 40°C



Bearingless pump systems for DC voltage supply BPS-1 and BPS-3